



Installation Constructions of 15kV Rear Connector with Arrester

(If you want to install rear connector with arrester after the Front Connector)

Installation steps:

1. You should take out the assembled nut, flat washer and spring washer.
2. Screwing in the conductive linking rod, compress tightly the cable lug in the front connector, and screwing in M16/M12 bolt.
3. Cleaning the inner holes and all the surface for installation, then wipe the silicone grease.
4. Push the rear connector with arrester into the tail hole of the front connector.
5. Set into the flat washer, spring washer, and nut, and tighten them with spanner.
6. Screwing the insulating plug, and then put on the cover cap.
7. Fixing on the earthing wire.

Notes:

1. The no-gap arrester is not allowed to do the frequency discharge voltage test.
2. The arrester is not allowed to do the insulating withstand test. And the preventive test must be done when put into operation before or after each full one year.
3. When installing and dismantling the arrester, your hands must grab the upper position of it, and use force evenly. Do not grab the end of the bolt in order to prevent the earth ear from being twisted off because of leverage.

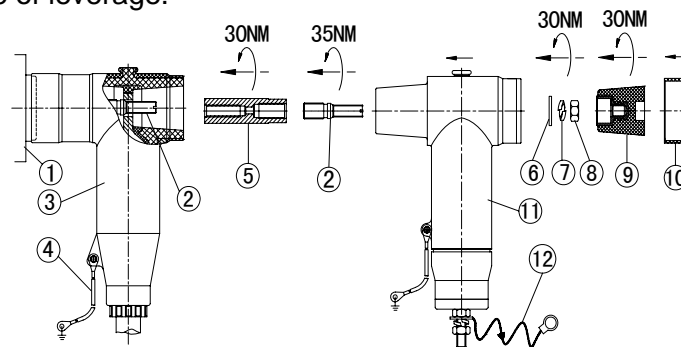

1. Bushing	5. Linking rod	9. Insulating plug
2. Coupling bolt	6. Flat washer ring	10. cover cap
3. Front connector	7. Spring washer ring	11. Rear connector with arrester
4. Earth wire	8. Nut	12. Tinned soft wire